



CETAC Technologies

14306 Industrial Rd.  
Omaha, NE 68144  
USA  
PHONE 402.733.2829  
FAX 402.733.5292  
WWW CETAC.com

# *ASXPRESS PLUS*

## **Rapid Sample Introduction System Quick Installation Guide**

Manual Part Number 610092



## ASXPRESS PLUS Quick Installation Guide

This guide shows you how to connect the ASXPRESS PLUS Rapid Sampling System to a CETAC autosampler *when they have been purchased together as a system*. If your autosampler was purchased separately, the autosampler requires additional preparation, described in the ASXPRESS PLUS Operator's Manual, which is available on the software CD or from [www.cetac.com](http://www.cetac.com).

Photos depicted in this guide may reflect models of the autosampler or ASXPRESS PLUS system which differ in application or version from the unit being installed. Therefore, differences in component appearance may be noted. This guide deliberately represents those models of differing components to represent all models that may be encountered.

This guide is for use by qualified chemists or laboratory technicians who are familiar with electrical and chemical safety precautions. See the ASXPRESS PLUS Operator's Manual for notices and safety information.

- 1 Unpack the ASXPRESS PLUS components and the CETAC autosampler.

**Note:**

Inspect all packaging materials for damage that may have occurred during shipment.

Refer to the packing lists included with both the ASXPRESS PLUS and autosampler to ensure that all components have been received.

Keep all shipping containers for use in the unlikely event that shipment is required for warranty or service work. The original packaging must be used for this purpose to ensure that the warranty remains valid.

## 2 Prepare the autosampler:

- a Attach the Z-drive assembly to the slider block guide rail.

**Note:**

The Z-drive assembly is different for each model of autosampler. The ASX-510 Z-drive is shown here.

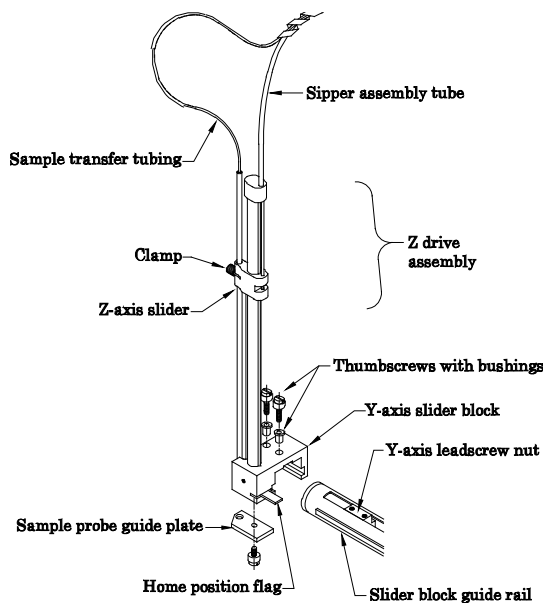

- b** Attach rinse tubing. The configuration of this tubing varies greatly depending on the autosampler being used, the rinse pump, and the application.

In general, connect a container of rinse solution to one input of a high-speed pump, and let the other input take in air; the outputs of the pump will be connected via a Y connector and then to the inlet port of the rinse station. The outlet of the rinse station will be connected to a waste container through a gravity drain or pump-assisted drain.

See the “Autosampler Rinse Station Liquid Flow Connections” diagram on page 10 and the Operator’s Manual for additional detail.

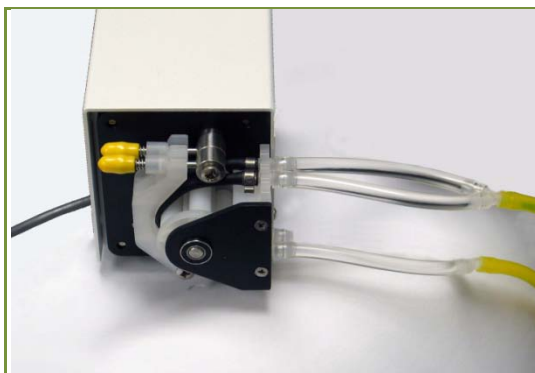

(External peristaltic pump for an ASX-510 shown.)

### 3 Prepare and position the ASXPRESS PLUS valve/pump module:

- a** Remove the protective cover from the 6-port valve.
- b** Attach the sample probe to port #2-grey.

**Note:**

Use only “Double Blue Band”, 1.0mm I.D. sample probes with the ASXPRESS PLUS system.

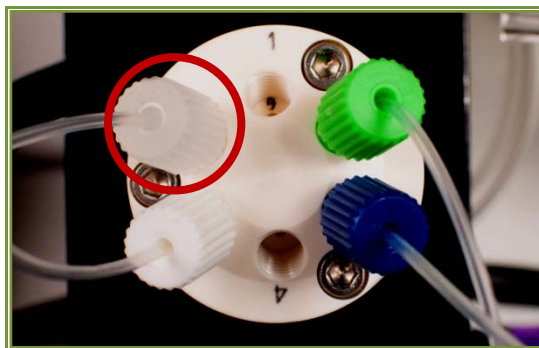

- c** Attach the sample loop between ports #1 and #4 on the 6-port valve.

**Note:**

Experiment with the loop size to determine the optimal size for your application, balancing sample size, sampling rate, and integration time. Several loops of varying sizes are supplied. See the ASXPRESS PLUS Accessories and Supplies Catalog for a full list of available sample loop sizes for aqueous and oils applications.

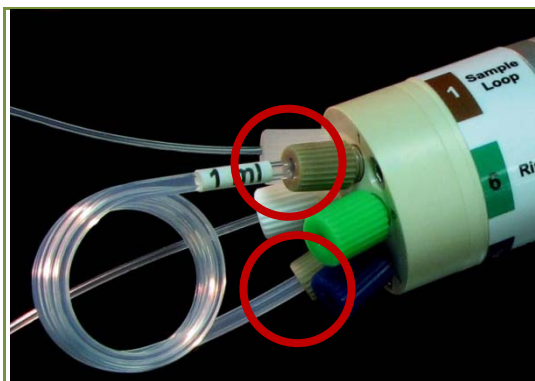

- d** Position the valve/pump module as close to the ICP nebulizer as possible. This may require adjusting vertical and horizontal placement of the valve/pump module, the orientation of the valve, or the orientation of the spray chamber. To accommodate additional placement convenience, the CETAC SP6572 Articulating Mounting System is available.

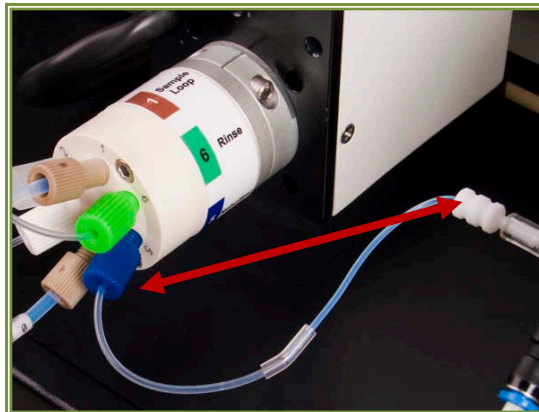

**Note:**

Minimize the tubing length between port #5 and the nebulizer to achieve the optimal time savings benefit of the ASXPRESS PLUS.

**ATTENTION:** Do not connect the nebulizer at this step. The photo shows some tubing as a reference (spliced to verify the length before cutting the final tubing). Further adjustments may be necessary before installation is complete.

- 4** Position the ASXPRESS PLUS electronics module and connect it to the valve/pump module with the attached cable.

**Considerations:**

- Place within 5 feet of the valve/pump module.
- Place within 5 feet of the autosampler rear panel.
- Place so that the operator is able to easily see the “load” and “inject” LEDs on the electronics module case.



- 5** Place the autosampler as near the ASXPRESS PLUS valve/pump module as is possible.

**Considerations:**

- Rinse station drain tubing connections
- Serial and USB cable connections
- Autosampler power supply connection

- 6** Connect the electronics module to its power supply.

**WARNING:** See the ASXPRESS PLUS Operator's Manual for electrical safety precautions.

- 7** Connect the host computer to the OEM COM port on the ASXPRESS PLUS electronics module. This will typically be an RS-232 serial connection to the port through which the application software (such as iTEVA™, WinLab32™, ICP-MS Expert™, or ChemStation™) sends commands to the autosampler.

**Notes:**

If the host computer does not have any free serial ports, a USB connection may be used. See “USB Connections.”

No null modem adapter is needed for the RS-232 connections.



- 8** Connect the autosampler's serial input port to the AUTOSAMPLER port on the ASXPRESS PLUS electronics module. (If the autosampler has more than one serial port, the input port is typically labeled “COM 1.”)



- 9** Connect the GUI COM port on the electronics module to the host computer. This will typically be an RS-232C serial connection.

**Notes:**

If the host computer does not have any free serial ports, a USB connection may be used, as shown here. See “USB Connections.”

You have now made *two* connections from the host computer to the electronics module: GUI COM (for configuring the electronics module) and OEM COM (for sending autosampler commands).



### USB Connections

Multiple communication cable options provide flexibility to use *all* RS-232, *all* USB or *a combination* of cables between the host PC and the electronics module. A USB driver must be installed to make the USB port emulate an RS-232 COM port, and the installation must be repeated for each USB connection.

To make a USB connection:

- a** Turn on the host computer and electronics module. Do *not* turn on the autosampler.
- b** Plug in the USB cable.
- c** Allow the Windows Found New Hardware Wizard to use Windows Update to search for a driver. In most cases, the driver will be found online and installed automatically. This process may take several minutes.
- d** If a driver is not found, insert the CD-ROM and allow the wizard to search the CD-ROM and install the driver (the exact procedure depends on the version of the Windows operating system). The hardware will be identified as an “FT 232R USB UART” and then as a “USB Serial Converter.”
- e** When driver installation is complete, make a note of which COM port number was assigned.

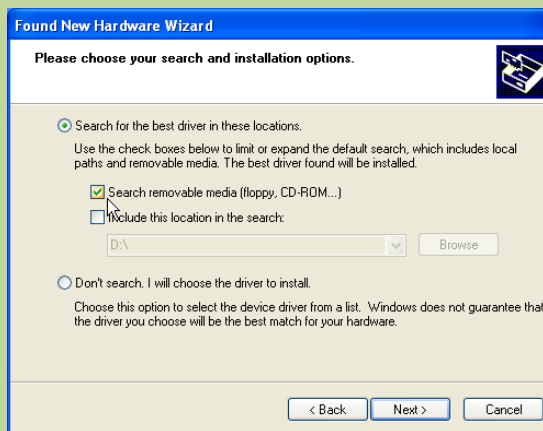

- 10** Connect the power supply to the autosampler, and to the mains power source. **Do not turn on the autosampler at this time.**

- 11** Install the sample probe onto the autosampler Z-drive assembly.

**Note:**  
The Z-drive assembly is different for each model of autosampler.

*(See the autosampler operator's manual for complete probe installation information.)*



(ASX-1400 is shown here.)

## 12 Connect the carrier/rinse solution:

- a** Prepare a carrier/rinse solution that is matrix-matched to your samples. A carrier/rinse solution bottle is provided with the ASXPRESS PLUS.



- b** Connect the carrier/rinse tee assembly to two lengths of peristaltic pump tubing (customer supplied) and install at the ICP instrument's peristaltic pump (see page 9). Connect one channel of the pump input to a pickup tube (shown, customer-supplied) for insertion into the carrier/rinse solution bottle. The input of the other channel of the pump remains open to the atmosphere, to draw in air. Note that the air is pumped into the tee assembly *perpendicular* to the liquid flow. The photo at right shows the supplied tee assembly connected to the customer-supplied peristaltic pump tubing and pickup tube.

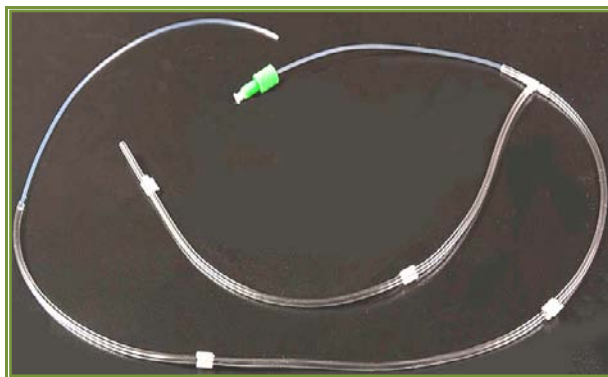

- c** Connect the opposite end (green fitting) of the carrier/rinse tee assembly to port #6-green of the ASXPRESS PLUS 6-port valve (see photo at right and the diagram on page 10 of this guide).

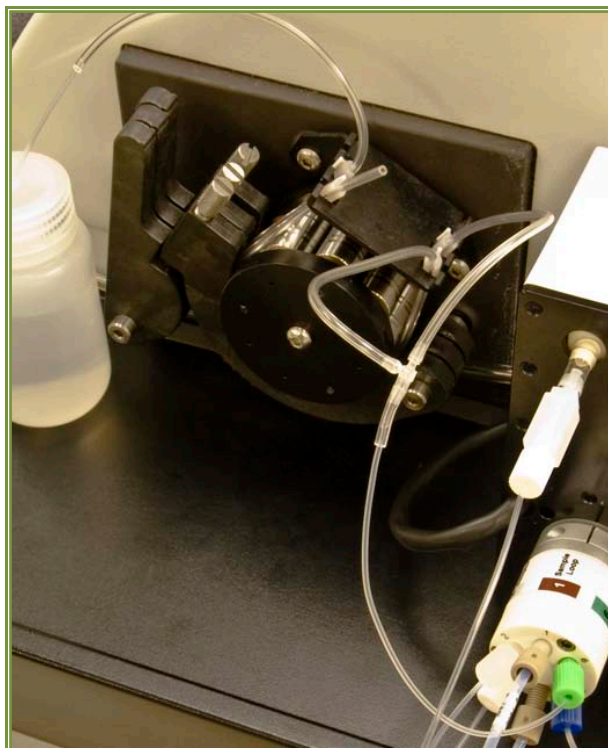

- 13** Connect all drain tubing (3 tubes) to an appropriate waste container.
- Autosampler rinse station drain tubing
  - ASXPRESS PLUS vacuum pump discharge “output” tubing
  - Nebulizer/spray chamber drain tubing

**Note:** Ensure that tubing ends are not submerged below liquid level in the waste container, as this can impede flow and affect performance of the ASXPRESS PLUS system. Use caution to arrange drain tubing so that waste may gravity drain completely without trapping any liquid in the line.

- 14** Join the nebulizer to the sample line at port #5-blue on the ASXPRESS PLUS 6-port valve using peristaltic pump tubing. Place a nut and ferrule on one end of the line to attach it to the nebulizer. To reduce carryover and ensure effective washout, use one continuous piece of tubing with no splices.

**Note:**  
Cut the line to the shortest possible length. This may also require reorienting the spray chamber to allow close-proximity placement of the ASXPRESS PLUS near the nebulizer.



- 15** Install the software onto the host computer from the included CD. To do so, follow the instructions found in the ASXPRESS PLUS Operator's Manual, which is available on the CD or from [www.cetac.com](http://www.cetac.com).
- 16** Refer to the ASXPRESS PLUS Operator's Manual for additional information on installation, setup or operation.

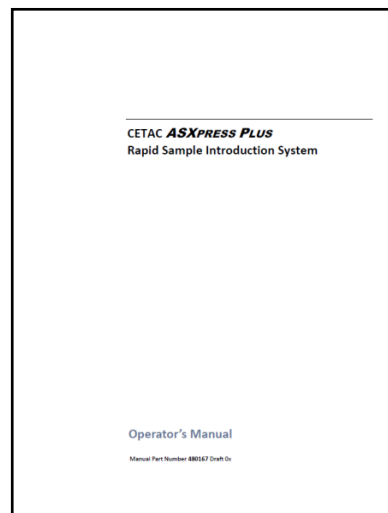

# Valve/Pump Module Liquid Flow Connections

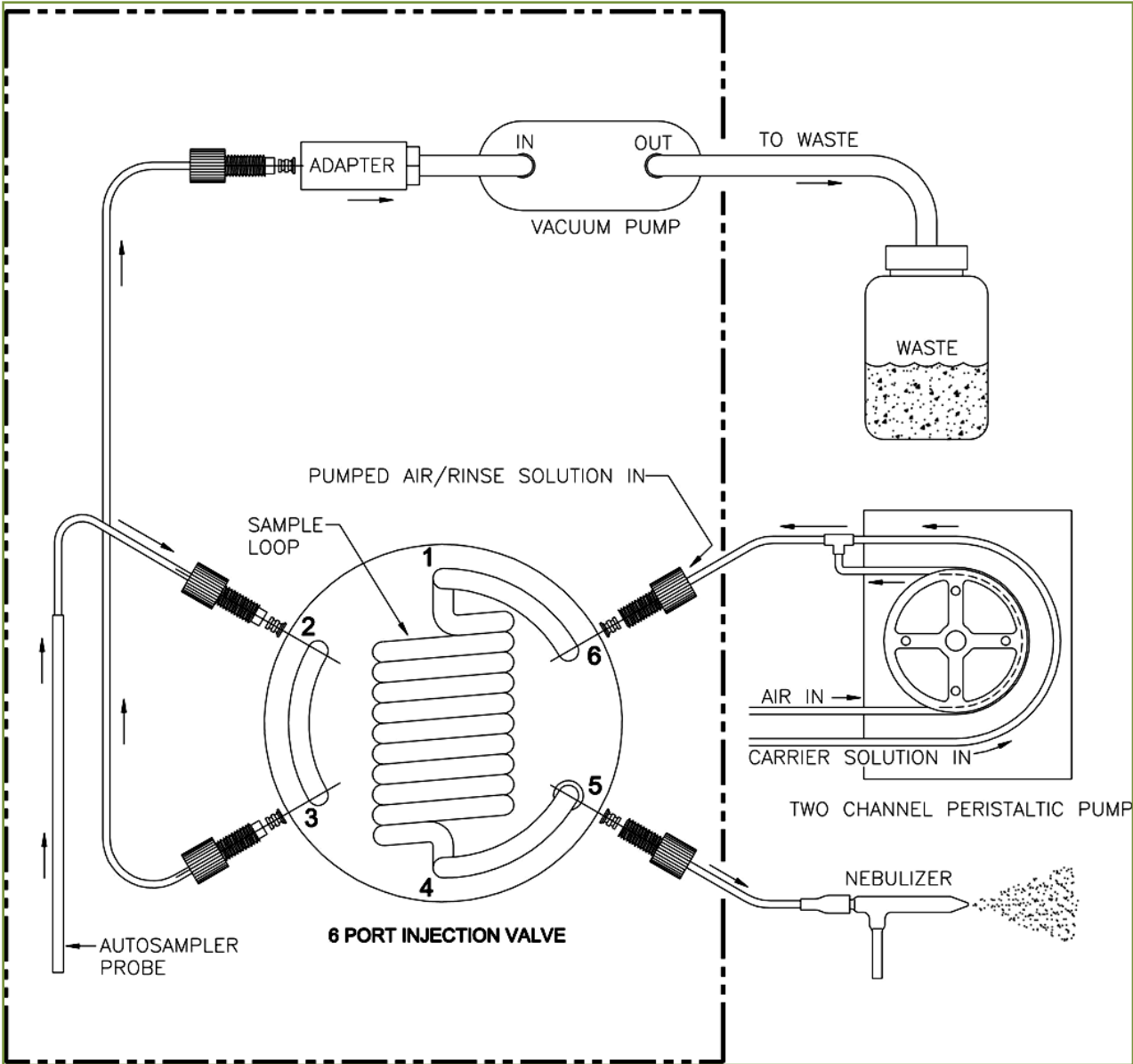

## Autosampler Rinse Station Liquid Flow Connections

General connections are shown. Some configurations may also include additional pumps. Refer to the ASXPRESS PLUS Operator's Manual or contact CETAC for further instruction, as required.

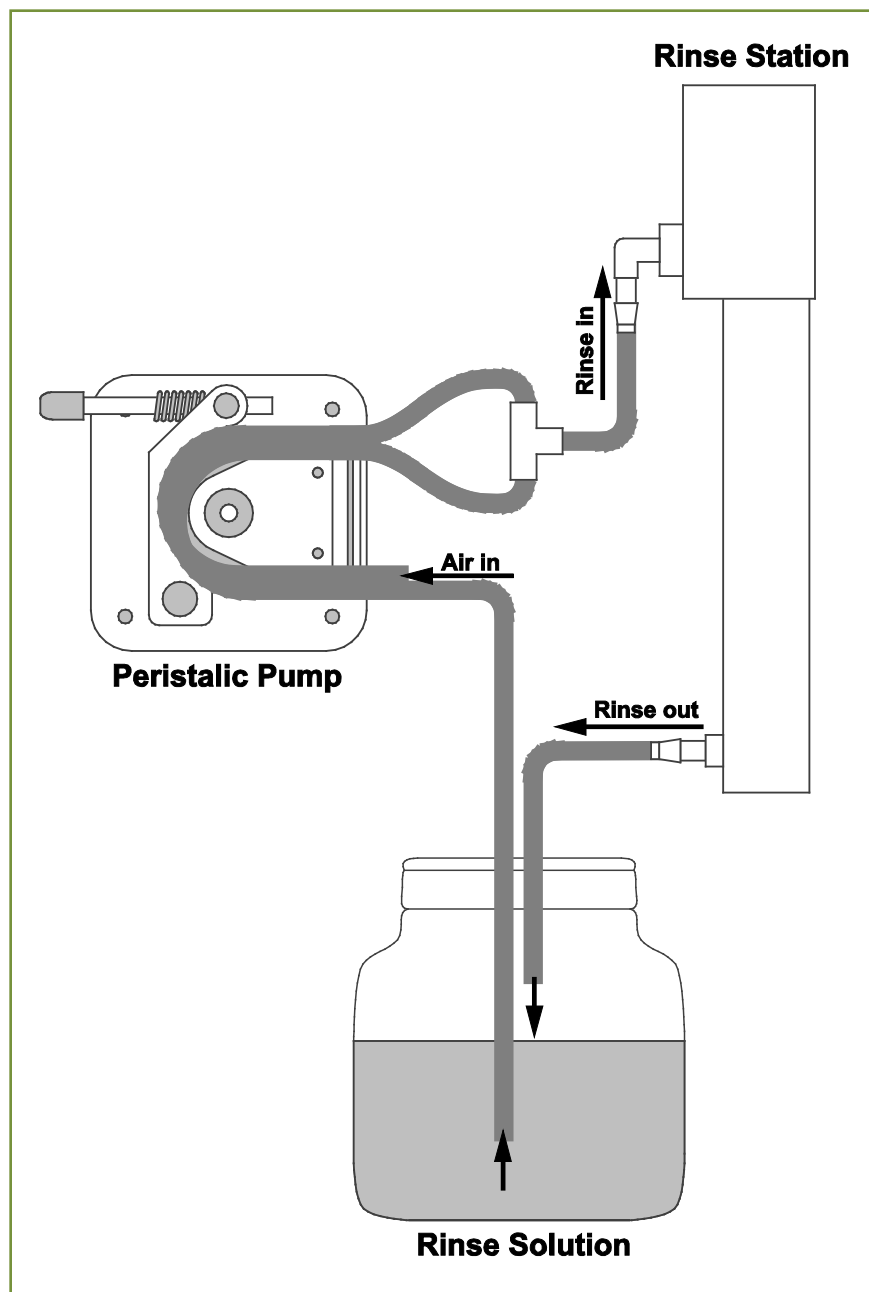

### Typical rinse connections for an ASX-500/510 autosampler with external peristaltic pump.

This configuration recycles the rinse solution, and uses a gravity drain for the rinse station. An external, tabletop peristaltic pump combines air and rinse solution to create bubbles, which help scrub the tubing. The autosampler's built-in peristaltic pump is not used.

## Autosampler Rinse Station Liquid Flow Connections (cont)

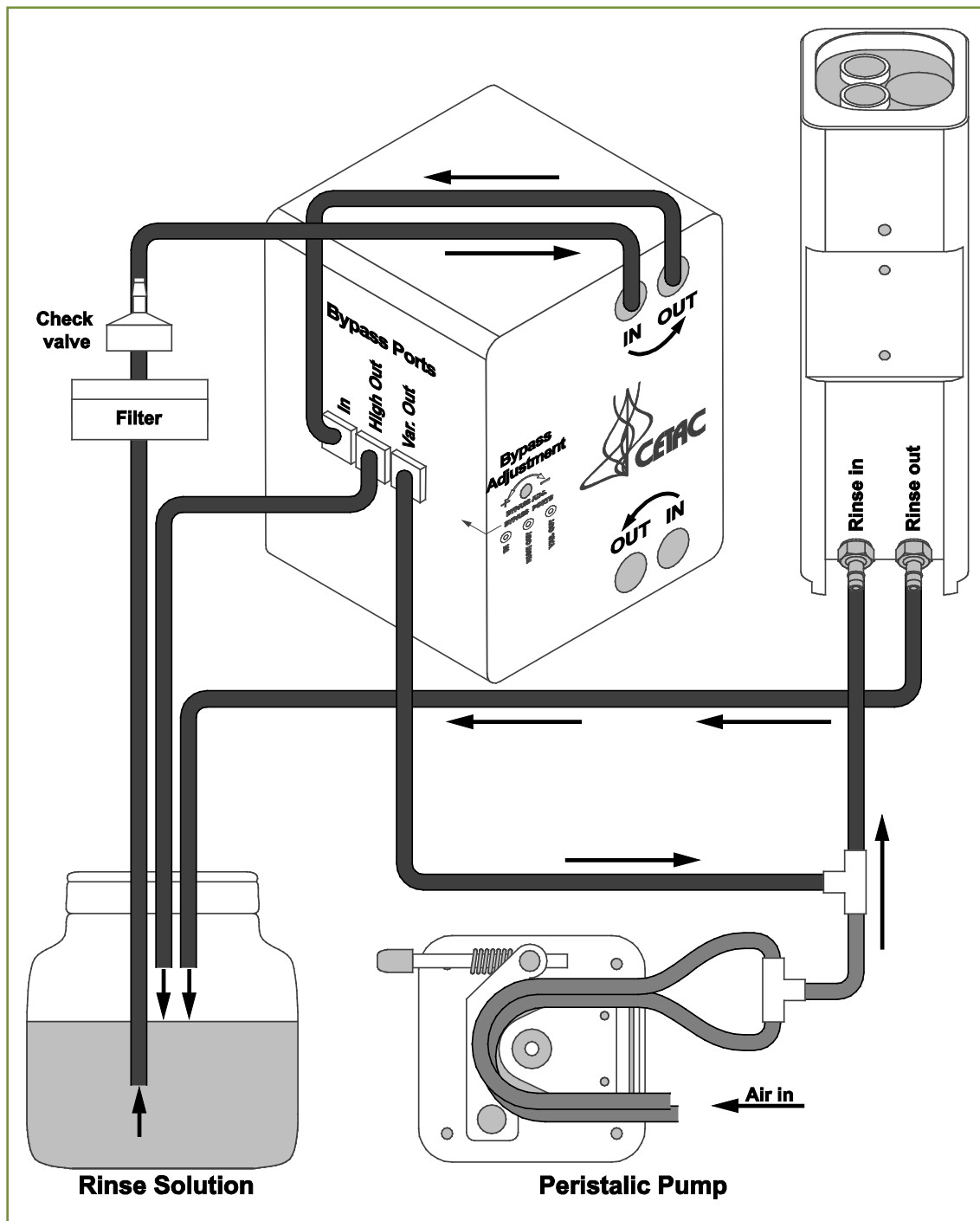

**Typical rinse connections for an ASX-1400/1600 autosampler with diaphragm pump and gravity drain.**

This configuration recycles the rinse solution, and uses a gravity drain for the rinse station. The diaphragm pump attaches to the back of the autosampler.

One or two channels of the autosampler's built-in peristaltic pump adds room air to create bubbles, which help scrub the tubing.

Recommended tubing: Air lines – Pharmed™; Rinse solution – Viton™, Tygon™ Fuel and Lubricant, or Superthane™.

### Autosampler Rinse Station Liquid Flow Connections (cont)

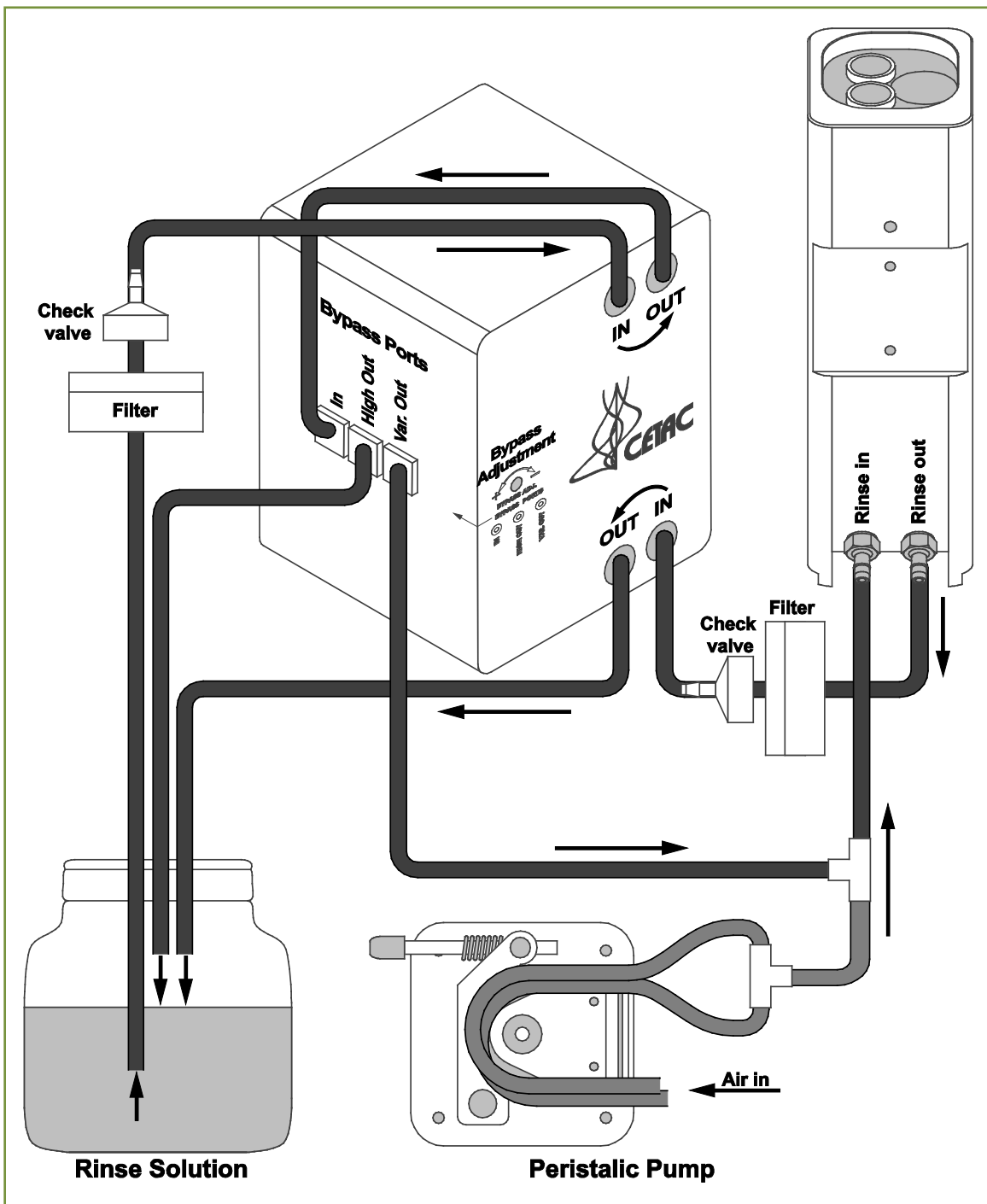

**Typical rinse connections for an ASX-1400/1600 autosampler with diaphragm pump and pumped drain.**

This configuration recycles the rinse solution, and uses the diaphragm pump to pull rinse solution from the rinse station. The diaphragm pump attaches to the back of the autosampler.

One or two channels of the autosampler's built-in peristaltic pump adds room air to create bubbles, which help scrub the tubing.

Recommended tubing: Air lines – Pharmed™; Rinse solution – Viton™, Tygon™ Fuel and Lubricant, or Superthane™.

## ASXPRESS PLUS Power/Communication General Connections

General connections are shown. Some configurations may also include additional pumps. Refer to the ASXPRESS PLUS Operator's Manual for further instruction, as required.

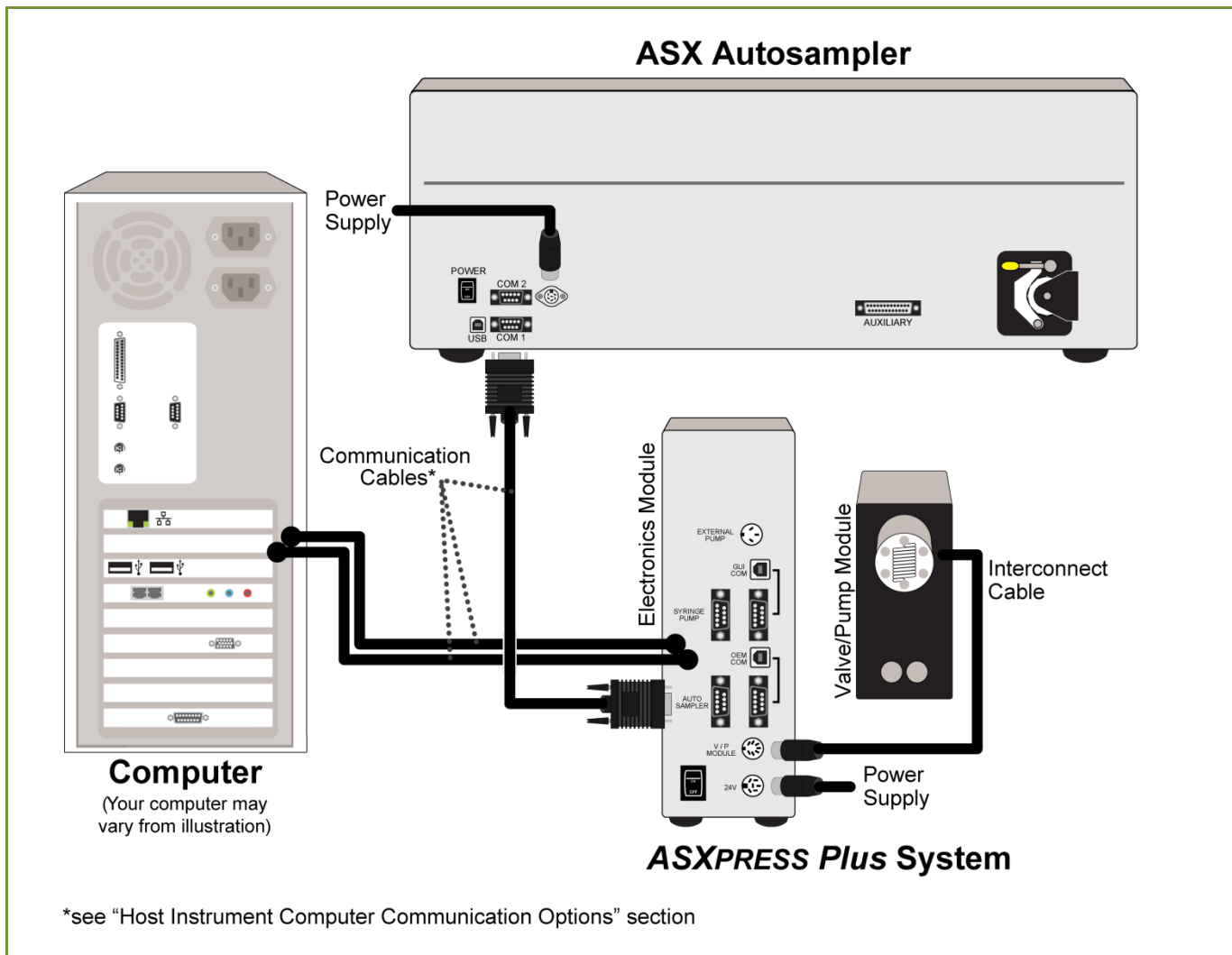

© 2010 SD Acquisition, Inc., DBA CETAC Technologies / Printed in USA / Revision: ASXpressPlus\_IG\_rev3.docx

Windows is a registered trademark of Microsoft Corporation in the United States and other countries. iTEVA is a trademark of Thermo Fisher Scientific Inc. WinLab32 is a trademark of PerkinElmer Instruments LLC. ICP-MS Expert is a trademark of Varian, Inc. ChemStation is a trademark of Agilent Technologies. PharMed and Tygon are registered trademarks of Saint-Gobain Performance Plastics. DuPont™, Kapton®, Tefzel® and Viton® are trademarks or registered trademarks of E.I. du Pont de Nemours and Company. All other marks are the property of their respective owners.

---