



CETAC Technologies

14306 Industrial Rd.
Omaha, NE 68144
USA
PHONE 402.733.2829
FAX 402.733.5292
WWW CETAC.com

ASXPRESS

Rapid Sample Introduction System Quick Installation Guide

Manual Part Number 610091



ASXpress Quick Installation Guide

- 1 Unpack the ASXpress and the ASX series Autosampler.

Note:

Inspect all packaging materials for damage that may have occurred during shipment.

Refer to the packing lists included with both the ASXpress and ASX series autosampler to ensure that all components have been received.

Retain all shipping containers for use in the unlikely event that shipment is required for warranty or service work. It is required that the original shipping containers be used for this purpose to ensure that the warranty remains valid.

2 Prepare the Autosampler:

- a Attach the Z-drive assembly to the slider block guide rail.

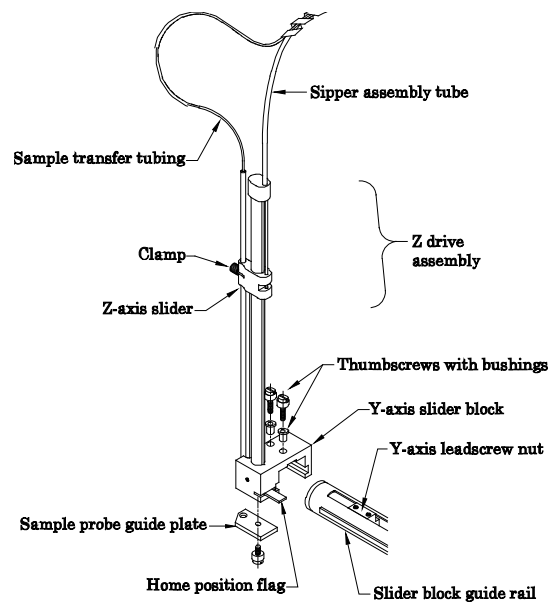

- b Attach rinse suction tubing to one (1) autosampler peristaltic rinse pump “inlet” (suction) port (see the “Autosampler Rinse Station Liquid Flow Connections” diagram in this guide for additional detail).

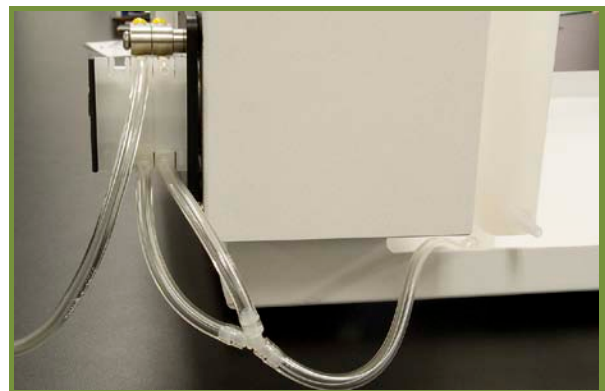

NOTE:

Photos depicted in this guide may reflect models of the ASXpress which differ in application or version from the unit being installed. Therefore, differences in component appearance may be noted. This guide deliberately represents those models of differing components to represent all models that may be encountered.

3 Prepare/Position the ASXpress Valve/Pump Module:

- a Remove the protective cover from the 6-port valve.
- b Attach the sample probe to port #2-grey.

Note:

Only “Double Blue Band”, 1.0mm I.D. sample probes shall be used with the ASXpress (except oils applications models which use a “Yellow Band”, 0.9mm ID sample probe).

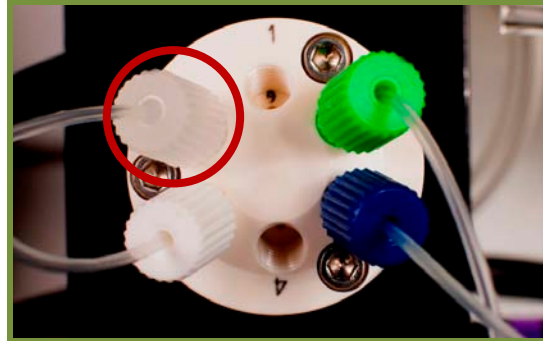

- c Attach the sample loop between ports #1 and #4 on the 6-Port Valve.

Note:

Some loop size selection experimentation may be required to determine the optimal size for your application, ensuring the most efficient and effective operation of the ASXpress. Thus, the ASXpress includes six (6) loops of varying sizes. See the ASXpress Accessories and Supplies Catalog for a full list of available sample loop sizes.

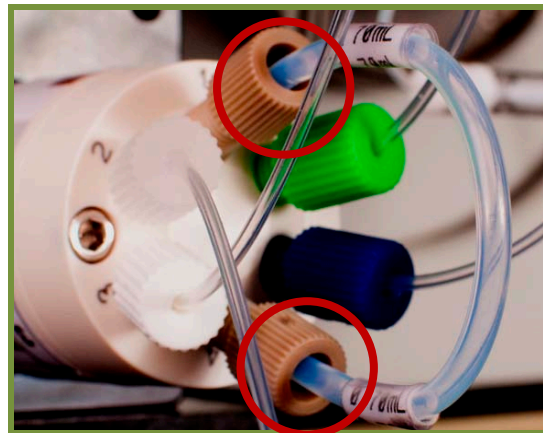

- d Position the ASXpress as close to the ICP nebulizer as possible. This may require adjusting vertical and horizontal placement of the ASXpress, as well as adjusting the orientation of the spray chamber to accommodate close proximity placement of the unit. To accommodate additional placement convenience, SP6572 Articulating Mounting System is available.

Note:

It is key to minimize the tubing length between port #5 and the nebulizer to achieve the optimal time savings benefit of the ASXpress.

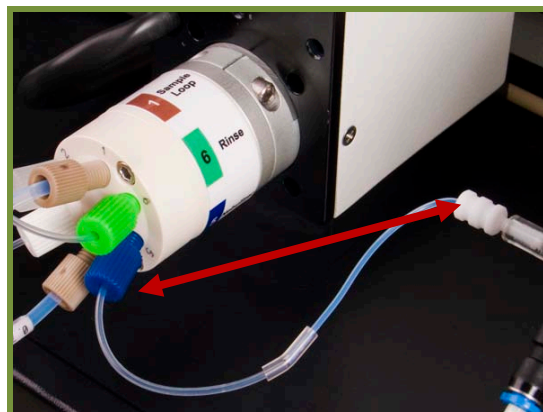

ATTENTION: Do not connect the nebulizer at this step. The prior photo was shown as a reference. Further adjustments may be necessary before installation is complete.

- 4** Position/connect the ASXpress electronics module to the ASXpress valve/pump module.

Considerations:

- Place within 5 feet of the valve/pump module.
- Place so that the operator is able to easily see the “load” and “inject” LEDs on the electronics module case.
- Place within 5 feet of the autosampler rear panel

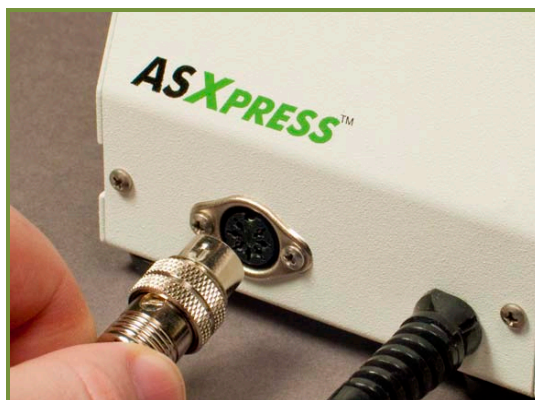

- 5** Place the ASX Autosampler as near the ASXpress as is possible.

Considerations:

- Rinse station drain tubing connections
- Com port cable connections
- Autosampler power supply connection
- ASXpress power/signal cable connection

- 6** Connect the ASXpress electronics module to the ASX series autosampler via the DB-37 cable to the ASX Auxiliary port.



- 7** Connect the ASX series autosampler (com 1 port) to the host computer serial port using the RS-232 communication cable. Option: The supplied USB cable may be used as an alternative to the RS-232 connection to the host computer (see schematics at the rear section of this Guide).



- 8** Connect the ASX series autosampler (com 2 port) to the host computer using the RS-232 communication cable (**with null modem adapter attached**). This cable is also provided with a USB to RS-232 adapter attached. *If the host computer has a second RS-232 port available, the USB to RS-232 adapter will not be necessary.*

Note:

The communication cable and null modem adapter (connected at Com port 2 on the autosampler) is used to allow bi-directional communication the Xpress Configuration Tool software on the host computer and the autosampler. The null modem adapter may be installed either at the autosampler or host computer end of the cable.

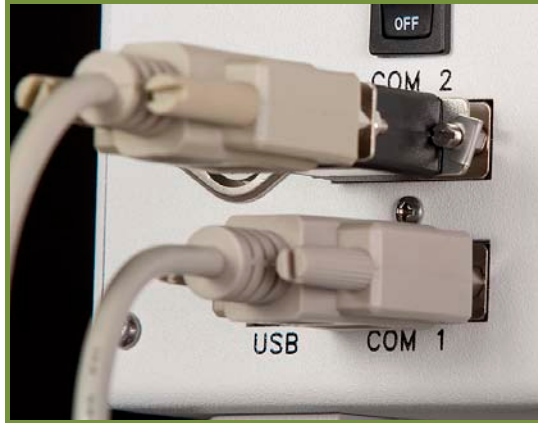
**Note:**

Multiple communication cable options provide flexibility to use *all* RS-232, *all* USB or a *combination* of communication protocol cables. However, the null modem adapter **must** be attached to the cable (either end) used at com 2 on the autosampler. When using the RS-232 to USB adapter, be sure to review the document titled *Guide to Driver Installation for the USB to RS-232 Adapter* (furnished both in hard-copy (with the adapter) and electronically (on the supplied CD-ROM)). Do **not** attempt to use or connect this adapter without first reviewing this document. Follow the instructions found in *that* document, at the appropriate step as is outlined in *this* document.

- 9** Complete this step if using the RS-232 to USB adapter:

When connecting the USB to RS-232 adapter-equipped com cable to the host computer, the Windows operating system will likely install the drivers automatically. **If it does not, you must install them manually from the supplied CD-ROM.** To do so, follow the instructions found on the "*Guide to Driver Installation for the USB to RS-232 Adapter*". This guide is supplied with the ASXpress in both hard copy and on the supplied CD (670068) in electronic form.

Caution:

Do not begin driver installation without first reading the above-noted Installation Guide (pictured at right). An inoperative adapter driver installation may result.

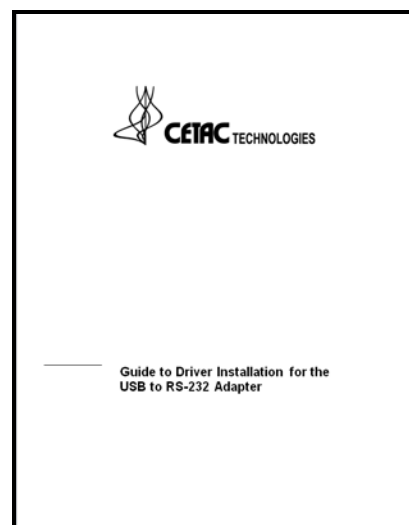

- 10** Connect the power supply to the ASX Autosampler, and to the mains power source. **Do not turn the power on the autosampler at this time.**

Note:

Do not turn the autosampler on at this time!



- 11** Review the communications and power cable schematics (found on the last pages of this guide) to ensure correct connection of cabling, as is dictated by your available host computer communication ports.

See pages 11 through 13 of this Install Guide!!!

- 12** Install the sample probe onto the ASX series autosampler Z-drive assembly.

Note:

The Z-drive assembly on older ASX models may differ from that shown at the right. Note that Z-drives equipped with two (2) probe clamps (near right) do not require a guide plate (far right).

(See the autosampler operator's manual for complete probe installation information.)

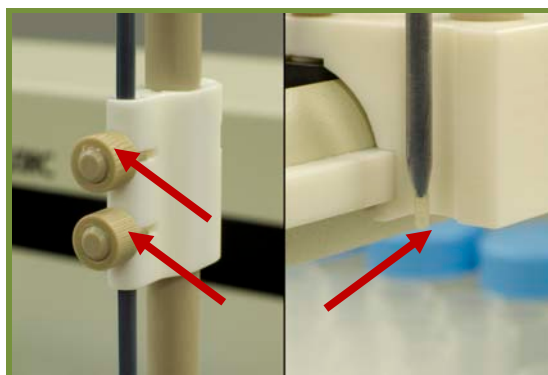

- 13 Connect the carrier/rinse solution:**

- a** Prepare a carrier/rinse solution that is matrix-matched to your samples. A carrier/rinse solution bottle is provided with the ASXpress.



- b** Connect the carrier/rinse tee assembly (see photo at right) to two lengths of peristaltic pump tubing (customer supplied) and install at the ICP instrument's peristaltic pump, as per the diagram found on page 8 of this manual. One channel of the pump input shall be connected to a pickup tube (shown, customer-supplied) for insertion into the carrier/rinse solution bottle. The input of the other channel of the pump remains open to the atmosphere, to draw in air. Note that the air is pumped into the tee assembly perpendicular to the liquid flow. The photo at right the supplied tee assembly connected to the customer-supplied peristaltic pump tubing and pickup tube.

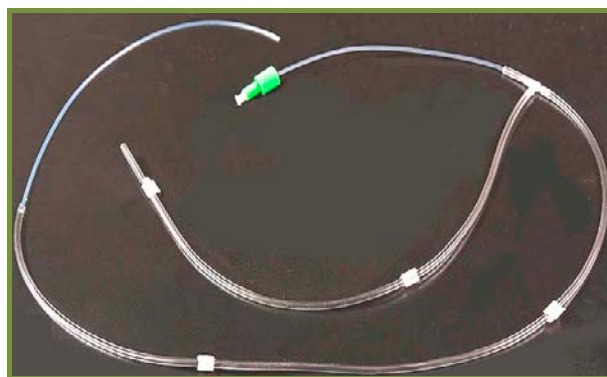

- c** Connect the opposite end (green fitting) of the carrier/rinse tee assembly to port #6-green of the ASXpress 6-port valve (see photo at right and the diagram on page 9 of this guide).

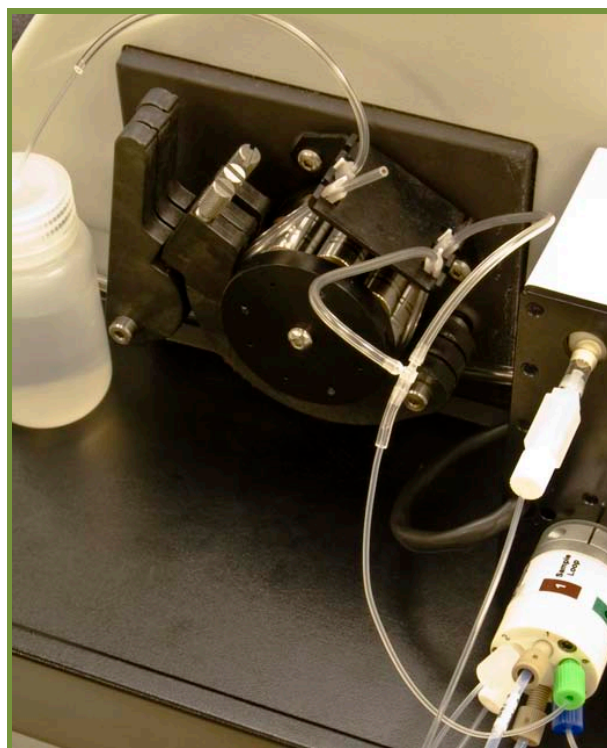

- 14** Connect all drain tubing (3 tubes) to an appropriate waste container.
- Autosampler rinse station drain tubing
 - ASXpress vacuum pump discharge "output" tubing
 - Nebulizer/spray chamber drain tubing

Note: Ensure that tubing ends are not submerged below liquid level in the waste container, as this can impede flow and effect performance of the ASXpress. Use caution to arrange drain tubing so that waste may gravity drain completely without trapping any liquid in the line.

- 15** Join the nebulizer to the sample line at port #5-blue on the ASXpress 6-port valve using peristaltic pump tubing.

Place a nut and ferrule on one end of the line to attach it to the nebulizer. To reduce carryover and ensure effective washout, use one continuous piece of tubing with no splices.

Note:

Cut the line to the shortest possible length. This may also require reorienting the spray chamber to allow close-proximity placement of the ASXpress near the nebulizer.

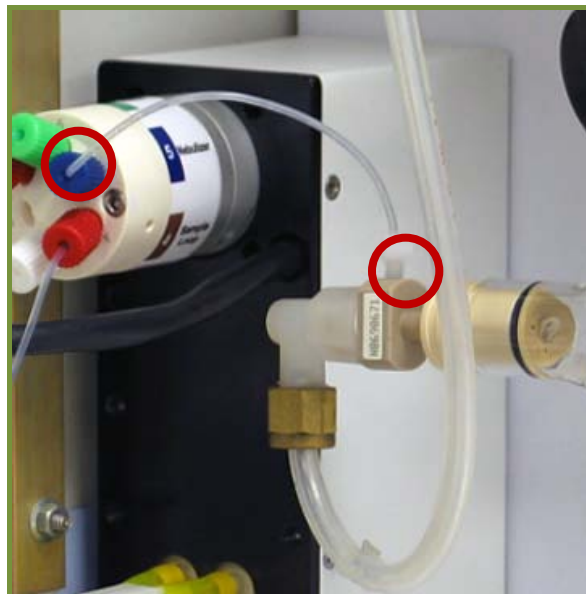

- 16** Install the software onto the host computer from the included CD. To do so, follow the instructions found in the ASXpress Operator's Manual.

- 17** Refer to the ASXpress Operator's Manual for additional information on safety, installation, setup and operation.

The ASXpress Operator's Manual is available on the software CD or from www.cetac.com.

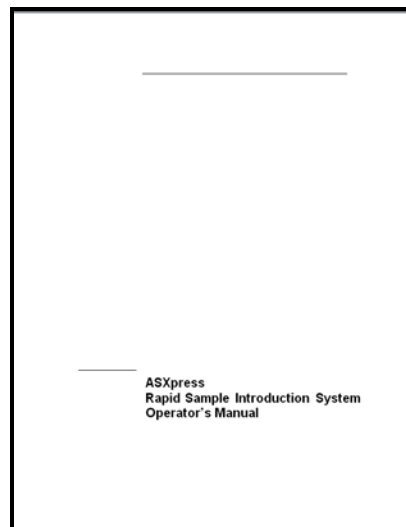

ASXpress Liquid Connections Diagrams

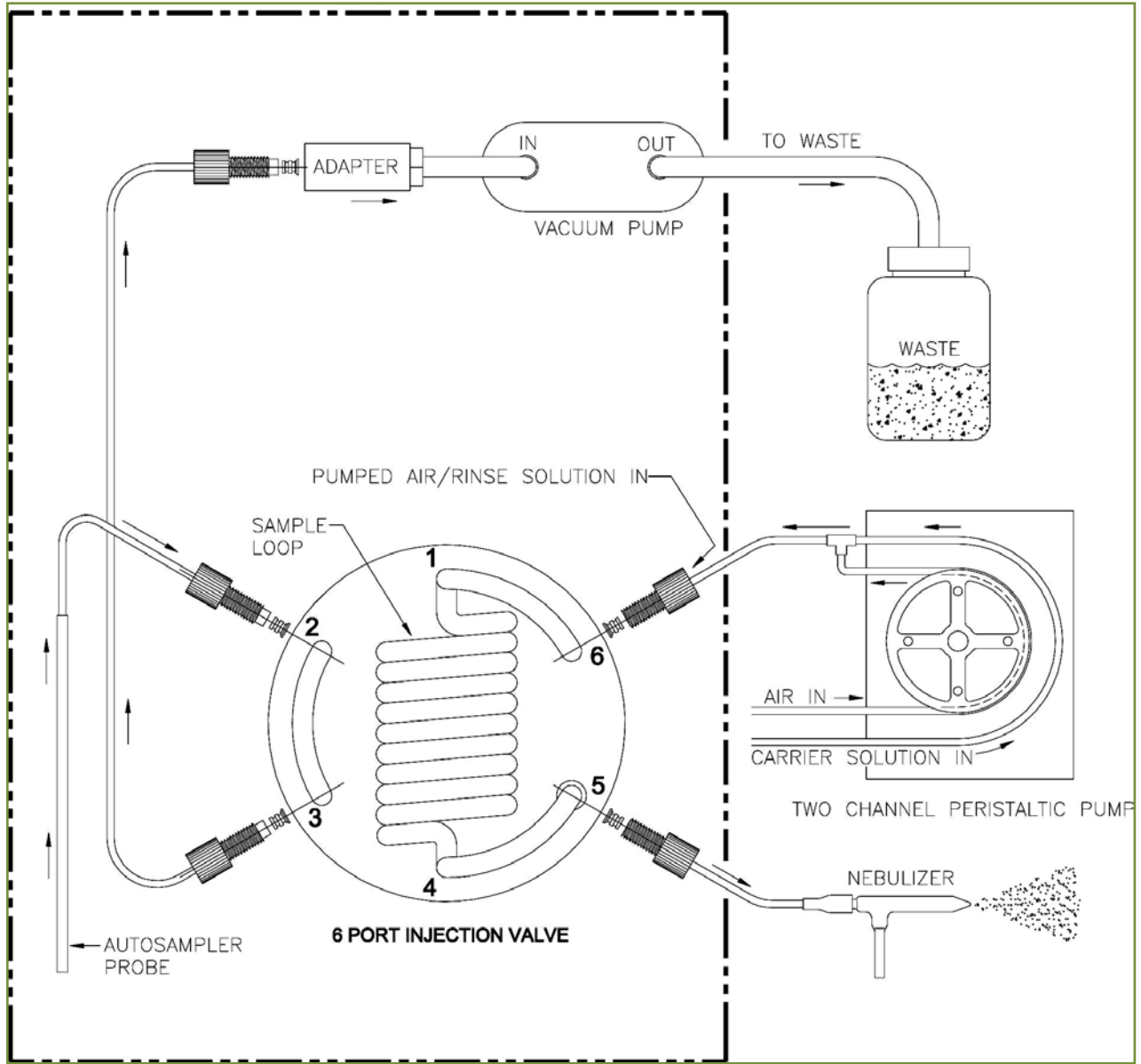

ASXpress 6-Port Valve Liquid Flow Connections

(6-port valve shown in the inject position)

ASXpress Liquid Connections Diagrams (cont.)

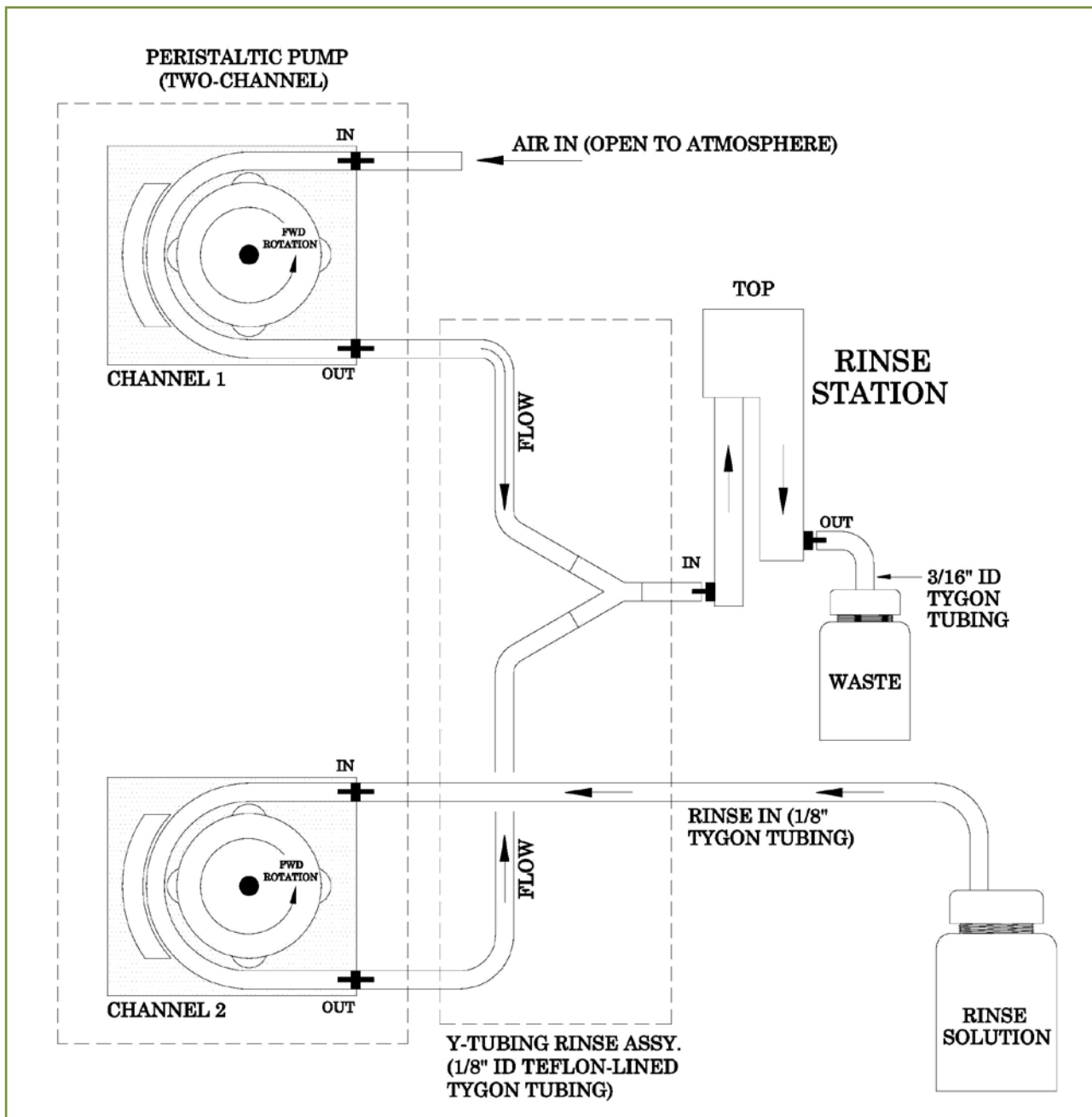

Autosampler Rinse Station Liquid Flow Connections

ASXpress Power/Communication Connections Diagrams

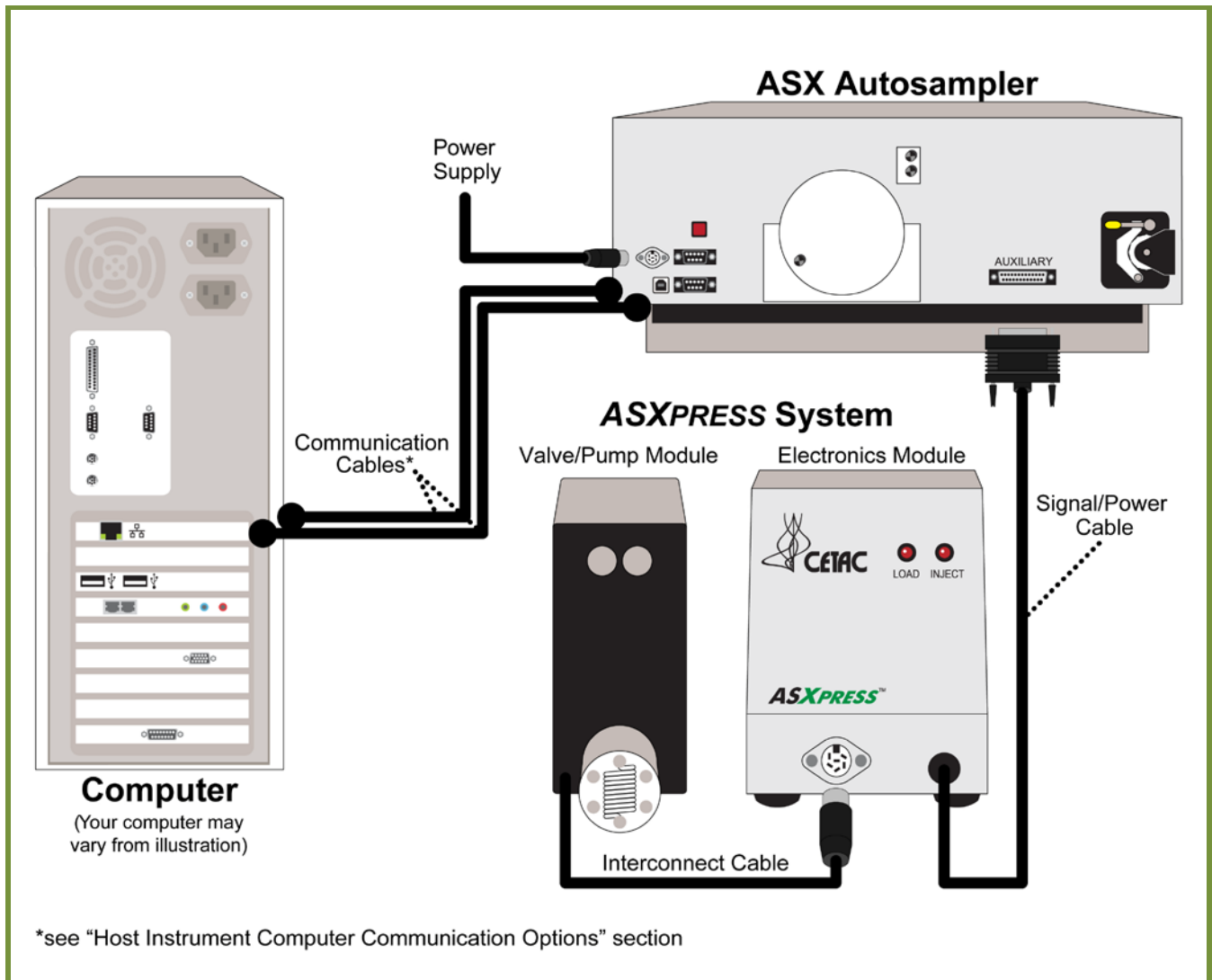

Power/Communication General Connections

(General connections are shown. For detailed ASXpress system/host instrument computer communication options which allow simultaneous communication of host instrument software and Configuration Tool software, see the schematics below. Refer to the ASXpress Operator's Manual for further instruction, as required.)

Host Instrument Computer Communication Options

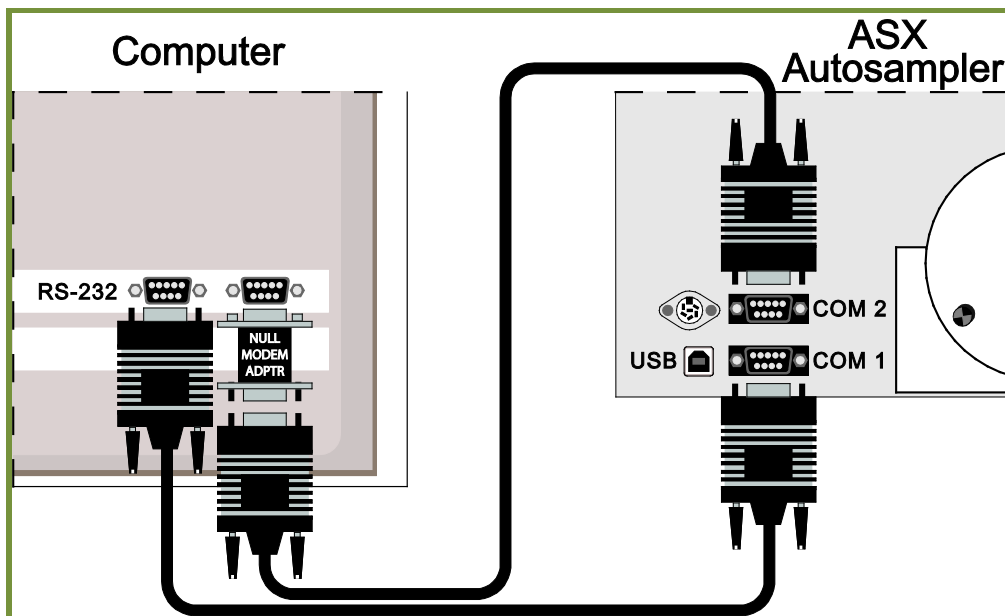

All RS-232 Communication

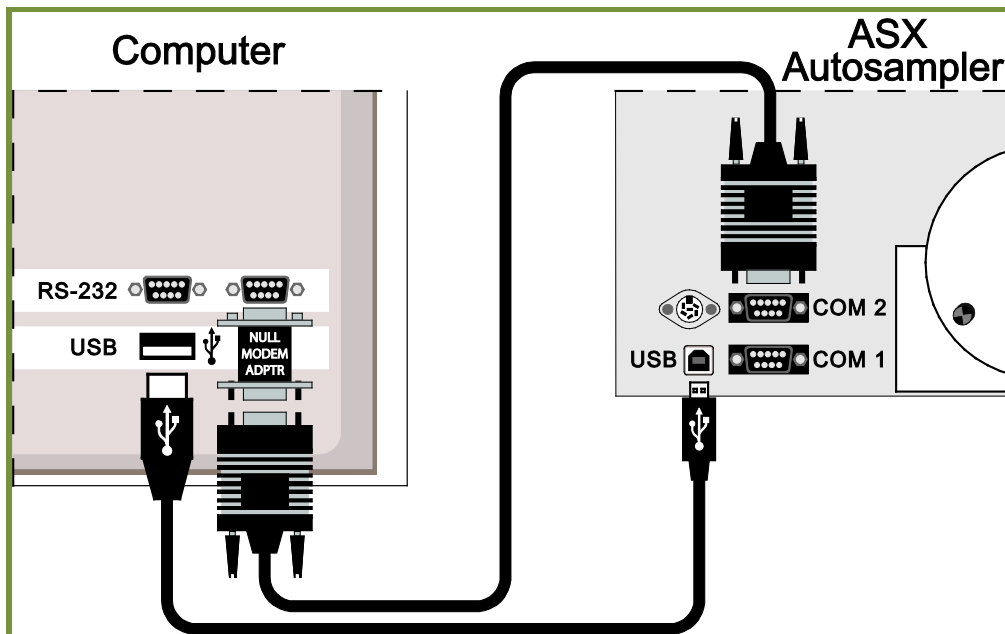

Combination of RS-232 and USB Communication (*no converter used*)

Host Instrument Computer Communication Options (cont.)

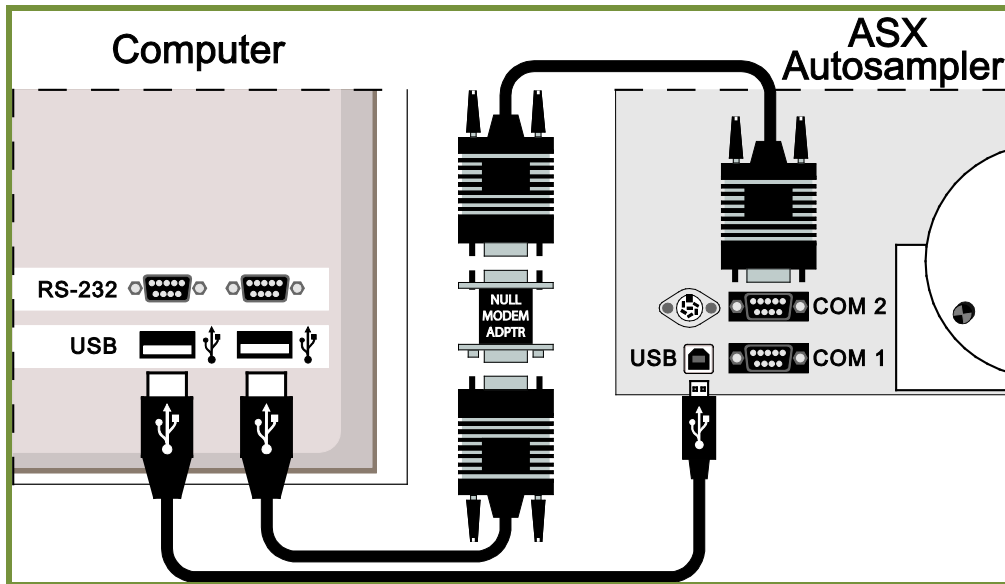

Combination of RS-232 and USB Communication (*RS-232 to USB converter used*)

If additional information is required, please refer to the ASXpress Operator's Manual, Accessories and Supplies Catalog or contact CETAC Technologies directly.

Windows is a registered trademark of Microsoft Corporation in the United States and other countries. iTEVA is a trademark of Thermo Fisher Scientific Inc. WinLab32 is a trademark of PerkinElmer Instruments LLC. ICP-MS Expert is a trademark of Varian, Inc. ChemStation is a trademark of Agilent Technologies. PharMed and Tygon are registered trademarks of Saint-Gobain Performance Plastics. DuPont™, Kapton®, Tefzel® and Viton® are trademarks or registered trademarks of E.I. du Pont de Nemours and Company. All other marks are the property of their respective owners.