

Rapid-Throughput Food Analysis by Inductively Coupled Plasma Atomic Emission Spectrometry

Dhinesh Asogan¹, Simon Nelms², Michael Sgroi³, Bill Spence⁴

¹ CETAC Technologies, 9 Alderman Walk, Stanford-le-Hope, UK ² Thermo Fisher Scientific, Stafford House, Boundary Way, Hemel Hempstead, UK.

³ CETAC Technologies, 14306 Industrial Road, Omaha, NE, USA. ⁴ CETAC Technologies, 17 Clearwater Drive, Manchester, UK.

ANALYSIS OF SODIUM IN FOOD

Biologically, sodium is essential for nerve function and maintaining fluid balance in the body. Too much sodium, however, increases the risk of high blood pressure, and is a major risk factor for kidney disease, heart disease and stroke.⁰⁻⁰

Approximately 75% of sodium present in processed foodstuffs is added through sweeteners (e.g. sodium saccharin), flavor enhancers (mono sodium glutamate), raising agents (sodium bicarbonate) and table salt (sodium chloride).

Because of the public concern over the health risks associated with excessive sodium intake, many food producers make claims about sodium levels in their products. In such cases, the sodium content must be displayed in a nutritional label. In the EU, nutritional information included in a food label is classified into two groups⁰

Group 1: displaying energy value and the amounts of protein, carbohydrate and fat

Group 2: as group 1 including sugars, saturated fats, fibre and sodium content.

Where there is a claim made about the sodium content in the food, e.g. 'Low Salt' or 'Less Salt', the nutrition label must be a Group 2 label.

In the USA, Federal Regulations state that all foods must display the amount of sodium present in the food in their nutrition label.⁰

In order to ascertain and check sodium content for labeling purposes, food producers must have their products analyzed. Consumer protection bodies must also perform such analyses to check the accuracy of labeling information and marketing claims.

Samples are typically acid digested in a microwave or on a hotplate in a mixture of mineral acids and then diluted with deionized water prior to measurement. One technique that can be used very effectively because of its wide linear dynamic range and high tolerance to dissolved solids is ICP-AES.

Due to the sample numbers that are often involved, high throughput analysis is an important requirement, as is minimizing cost per sample within the service laboratory environment.

This note discusses the use of the CETAC ASXPRESS[®] PLUS Rapid Sample Introduction System as a method of increasing sample throughput along with a new rapid integration method, termed Sprint mode, on the Thermo Scientific iCAP 6500 ICP-AES.

CETAC ASXPRESS[®] PLUS

The CETAC ASXPRESS[®] PLUS Rapid Sample Introduction System, when coupled to a CETAC autosampler, optimizes sample introduction by significantly increasing sample throughput and reducing costs of materials, power, maintenance and labor for ICP-AES analysis. The system is designed to allow multiple functions to occur simultaneously, which would otherwise take place separately.



Figure 1 – ASXPRESS[®] PLUS Rapid Sample Introduction system

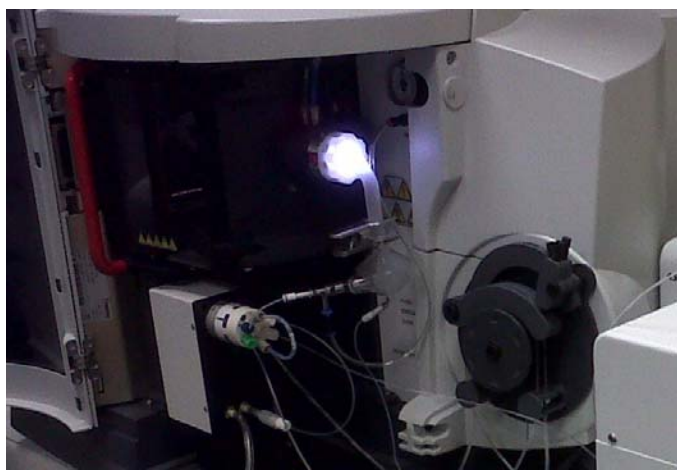

Figure 2 – ASXPRESS® PLUS with a Thermo Scientific iCAP 6500 Duo View ICP-AES

A standard sample uptake system (Figure 3) relies on a single peristaltic pump to deliver samples from the auto-sampler to the nebulizer and to rinse the sample flow path between sample deliveries. In addition to the ICP-AES peristaltic pump, the ASXPRESS® PLUS system utilizes a high speed vacuum pump together with a 6-port switching valve (Figure 4).

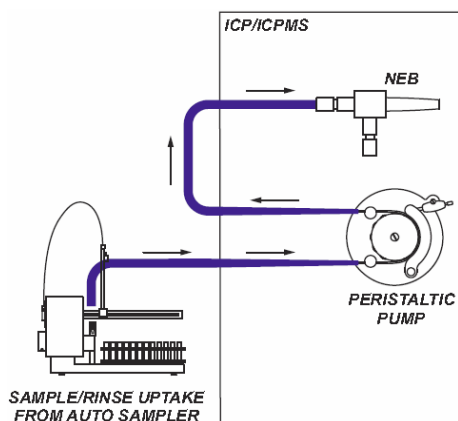

Figure 3 – Standard sample uptake system

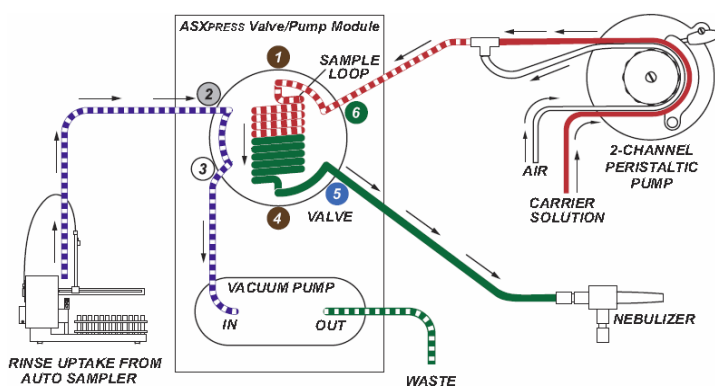

Figure 4 – ASXPRESS® PLUS Rapid Sample Introduction system in the 'Inject' position

The 6-port valve allows the use of both pumps simultaneously, reducing total sample analysis time significantly by effectively dividing each analysis into two stages. With the valve in the load position the vacuum pump rapidly fills the sample loop whilst the ICP-AES peristaltic pump simultaneously transports carrier/rinse solution to the nebulizer, keeping the plasma stable and the nebulizer clean.

Switching the valve to the 'inject' position allows the carrier solution, pumped by the peristaltic pump, to push the loaded sample from the loop into the nebulizer for analysis. Simultaneously, the autosampler probe is moved to the rinse station and the vacuum pump flushes rinse solution through the sample uptake path.

This strategy allows each stage of the sample uptake to be treated separately. One stage is rinsed whilst the other handles the sample, thereby minimizing time lost through rinsing. Additionally, the sample never comes into contact with peristaltic pump tubing, which can be a source of contamination.

TIME AND COST SAVINGS

The iCAP 6500 was set up with the ASXPRESS® PLUS system incorporating a 500 µl sample loop. The iTEVA method utilized 'sprint' mode with three replicate 1 second radial integrations. The method also utilized line switching (Na 589nm and Na 818nm) to enable low and high concentrations of Na to be determined in a single analytical run, which results in a total analytical measurement time of 9 seconds (including replicates and line switching).

Using the standard sample setup, the total analysis time was 45 seconds per sample, which includes 16 seconds sample flush time and 20 seconds rinse time. With the ASXPRESS® PLUS system, this was reduced to 16 seconds, which comprised 7 seconds flush time (4 seconds loop load with 3 seconds stabilization) and no rinse time.

This time saving represents an increase in sample throughput by a factor of 2.8, whilst also reducing the cost to run each sample by 64%.

DATA QUALITY

Two calibrations are presented below (Figure 5 and Figure 7): full calibration range at the Na 818.326 nm line and low standards at the Na 589.592 nm line. Both calibrations exhibit excellent linearity and low limits of detection, with predicted MDLs of 0.31 ppm and 0.01 ppm for the 818.326 and 589.592 nm lines respectively.

STABILITY AND CARRY-OVER

A stability run, comprising 60 replicates of the 100 ppm standard, was performed to assess the accuracy and precision of the analysis using the ASXPRESS® PLUS system. The mean recovery was found to be 101.52 % with a RSD of 1.09 %

To assess the carry-over associated with the ASXPRESS® PLUS system, an alternating set of samples comprising the blank, the 50 ppm standard and the 250 ppm standard was run. The results show minimal carry-over, and suggest the sample uptake path and sample loop is effectively cleared and rinsed before the next sample is introduced.

LOW MAINTENANCE COST

The maintenance procedures required for the ASXPRESS® PLUS system are extremely simple and quick. Routine maintenance includes disassembling the valve body and using compressed air to blow out the sampling ports and the rotor typically on a weekly basis, depending on sample volume and matrix.

Operation with the ASXPRESS® PLUS greatly extends the service life of ICP components, reducing nebulizer and spray chamber maintenance by limiting exposure to the sample matrix. Since peristaltic pump tubing is never exposed to the sample matrix, the service life of the pump tubing may also be enhanced and memory effects can be reduced.

EASE OF INSTALLATION

An easy, out-of-the-box set of instructions and initial configuration parameters have been developed for the ASXPRESS® PLUS to allow the utmost ease of installation. The ASXPRESS® PLUS integrates quickly and easily into the sample flow path, without modification to the overall analysis method. A simple and convenient Windows® based configuration tool is used to store parameters to the system's on-board processor. No additional software is required. Installation by an authorized service representative is available; please contact CETAC or ThermoFisher Scientific for details.

CONCLUSION

Use of the ASXPRESS® PLUS Rapid Sample Introduction system results in accurate and stable, high throughput analysis of sodium with low limits of detection. In this application, throughput on a Thermo iCAP 6500 ICP-AES can be increased by a factor of 2.85 with a reduction in cost-per-sample of 64%.

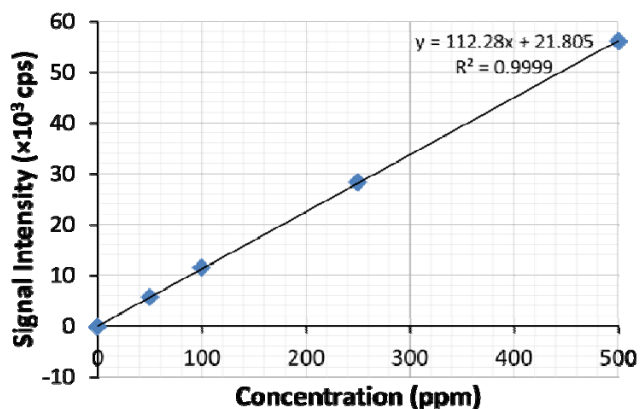

Figure 5 – Na 818.326 nm Calibration: full calibration range with a predicted MDL of 0.31 ppm

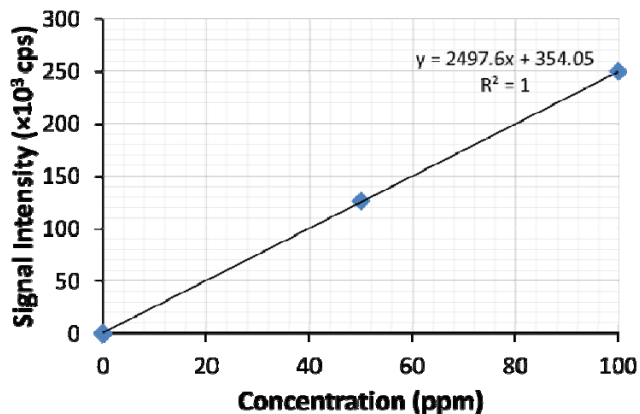

Figure 6 – Na 589.592 nm calibration: low standards with a predicted MDL of 0.01 ppm

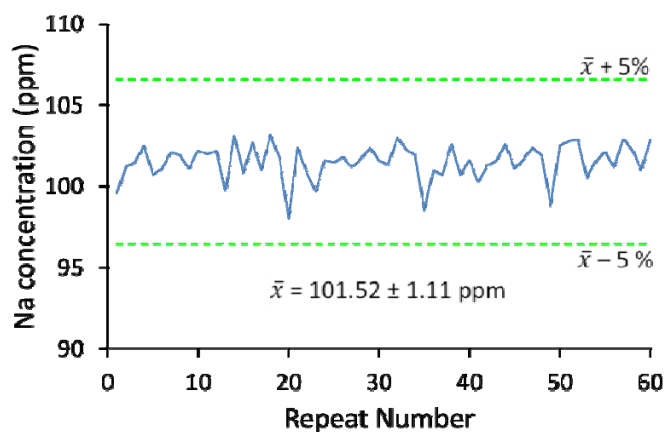

Figure 7 – 60 replicate Quality Control checks of a 100 ppm standard with upper and lower warning limits ($\bar{x} \pm 5\%$), highlighting accuracy and precision achieved with the ASXPRESS® PLUS system

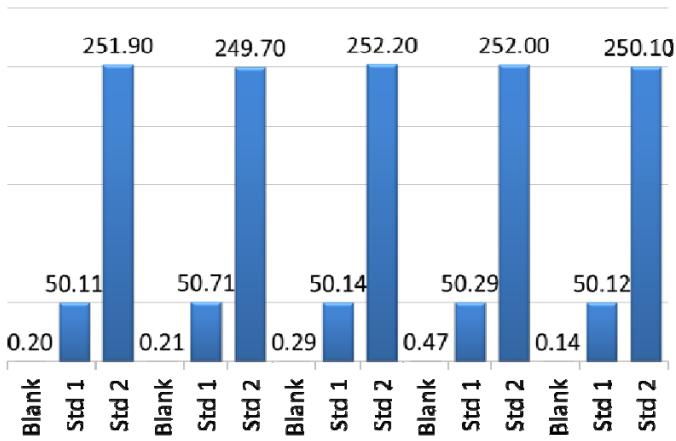

Figure 8 – Alternating sequence of Blank, 50 ppm standard (Std 1) and 250 ppm standard (Std 2) showing minimal carryover through the ASXPRESS® PLUS system

REFERENCES

Cordain, L.; Eaton, S. B.; Sebastian, A.; Mann, N.; Lindeberg, S.; Watkins, B.; O’Keefe, J. H.; Brand-Miller, J., *Am. J. Clin. Nutr.*, **2005**, Vol. 81 (2), pp. 341 – 354

Antonios, T. F. T.; MacGregor, G. A., *Lancet*, **1996**, Vol. 348 (9022), pp. 250 – 251

Massey, L. K.; Whiting, S. J., *Nutr. Rev.*, **1995**, Vol. 53 (5), pp. 131 – 139 [Abstract]

Devine, A.; Criddle, R. A.; Dick, I. M.; Kerr, D. A.; Prince, R. L., *Am. J. Clin. Nutr.* **1995**, Vol. 62, pp. 740 – 745

Directive 90/496/EEC, OJ L276, p. 1 of 6/10/1990

21 CFR §101.9